

SOLAR DIFFERENTIAL TEMPERATURE CONTROLLER DDT2

USER MANUAL

Description of the controller

DDT2 is a digital differential thermostat (the controller) for solar water heating and other applications with one relay output and two inputs for temperature sensors.

Technical data

Power supply input: 230 V AC **Output switch:** single pole relay **Maximal current through relay:** 3 A **Switching difference:** from 0.5 to 20.0 °C, step 0.5 °C **Hysteresis:** from 1.0 to 19.0 °C, step 0.5 °C **Measuring range:** from -28.0 to 99.5 °C **Accuracy:** ±0.5 °C **Controller operating environment:** from 5 to 40 °C **Software version:** 2005

Controller parts

The controller consists of the front panel, with alphanumeric liquid crystal display (LCD) and two buttons, and the case.

The display on the front panel (in default view) shows both measured temperatures in degrees Celsius: temperature A, temperature B, and their difference when applicable. It also indicates the current operational status of the running mode and of the relay output (**R:1** – on, **R:0** – off).

The display features a background light that is activated by pressing any key. When background light is active, the left button has SELECT/CONFIG function and the right button has UP/DOWN function. When no button is pressed for approximate 15 seconds, backlight turns off.

The case also houses power supply and screw terminals for connecting wires. For more information about wiring see section [installation](#).

Running modes

The controller can run in one of the five modes: MODE OFF, MODE ON, MODE ONE (differential thermostat), MODE TWO – HEATING (thermostat) or MODE THREE – COOLING (inverse thermostat).

In first two modes, output relay is constantly turned on or off, regardless of the temperature readings. In remaining three modes the controller operates by comparing measured and stored values and then decides the state of the output relay.

To select running mode or set the hysteresis (made of first, $\Delta 1$, and second difference, $\Delta 2$), refer to [configuration](#) section.

MODE ONE (differential thermostat)

This mode is commonly used in solar heating and other applications with daily variable temperature of energy source.

The controller running this mode compares five values: measured source temperature at sensor A (T_A), measured sink temperature at sensor B (T_B), minimal starting temperature (T_{start}), depletion limit – sufficient temperature to keep it running – (T_{stop}) and target point temperature (T_{heat_to}).

The controller will switch relay output on, and will show ▲ (black triangle up) next to relay output status, when all the following three conditions are satisfied:

- measured source temperature T_A is greater or equal minimal starting temperature T_{start} ,
- measured sink temperature T_B is less than target temperature T_{heat_to} , and
- the difference between measured source temperature T_A and measured sink temperature T_B , i.e. $T_A - T_B$, is above or equal to Δ_{ON} degrees.

When the difference $T_A - T_B$ falls below or is equal to Δ_{OFF} degrees (the last criterion is not satisfied), the controller displays ▼ (black triangle down) and switches relay output off.

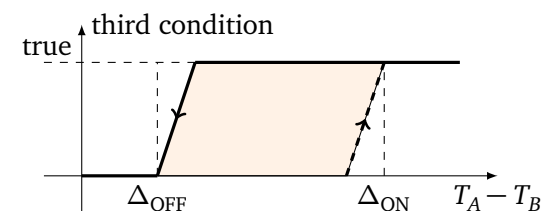

Furthermore, if measured temperature T_B reaches target point temperature, i.e. $T_B \geq T_{heat_to}$, then the controller displays **Tm** and the relay switches off. When measured temperature T_B falls below T_{heat_to} for $\Delta 2$ degrees, status of output relay depends also on the temperature T_A as described in this paragraph.

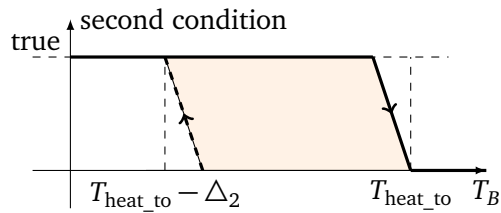

When the starting temperature has not been reached, the controller displays a negative value, i.e. the difference $T_{\text{start}} - T_A$, that is the difference between measured source and starting temperature. If the starting temperature has been reached the first condition will stay true until measured source temperature T_A is less or equal to T_{stop} .

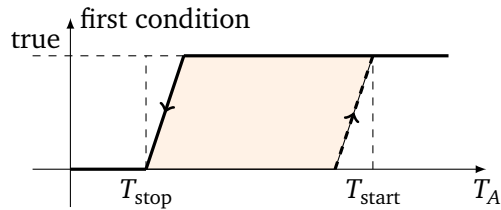

Note, that relay response might be delayed due to relay delay protection.

Turn on Δ_{ON} and turn off Δ_{OFF} difference

Values of Δ_{ON} and Δ_{OFF} are derived from $\Delta 1$ and $\Delta 2$ as minimum and maximum. For instance, if $\Delta 1 < \Delta 2$, then $\Delta_{\text{OFF}} = \Delta 1$ and $\Delta_{\text{ON}} = \Delta 2$. When $\Delta 1 = \Delta 2$, then $\Delta 1$ and $\Delta 2$ are adapted, eg. $\Delta 1$ lowers for 0.5 degrees and $\Delta 2$ increases for 0.5 degrees.

MODE TWO (thermostat for heating)

In this mode, the controller compares two values: measured temperature at sensor A (T_A) and target point temperature ($T_{\text{heat_to}}$) as follows and it is suitable for turning on the heater (for more powerful heater an additional external relay must be used).

When the measured temperature T_A falls below target temperature $T_{\text{heat_to}}$ for $\Delta 1$ degrees, the controller will display \blacktriangledown , negative temperature difference, and will switch relay output on.

When the temperature T_A rises above $T_{\text{heat_to}}$ for $\Delta 2$ degrees, the controller displays \blacktriangle , positive temperature difference, and switches relay output off.

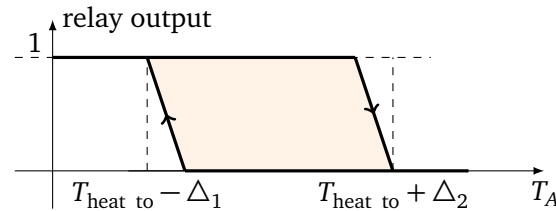

MODE THREE (thermostat for cooling)

This mode is opposite of previous mode and suitable for cooling with air conditioner.

When the measured temperature T_A rises above target temperature $T_{\text{cool_to}}$ for $\Delta 1$ degrees, the controller will display \blacktriangle and will switch relay output on.

When the temperature T_A falls below $T_{\text{cool_to}}$ for $\Delta 2$ degrees, the controller displays \blacktriangledown , negative temperature difference, and switches relay output off.

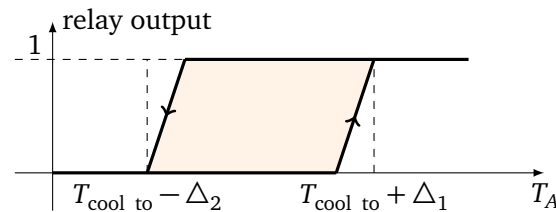

MODE ON and MODE OFF

These two modes are most used for testing connection to the pump and when operation of pump is not

desired, e.g. winter time.

Note that MODE OFF does not disconnect power to the pump completely.

Other functions

Warning indicator

When an error occurs: absent sensor, sensor reading error, insufficient flow or overheat protection, the display backlight blinks each second.

Indicator of insufficient flow

If the temperature of source increases for additional 2 °C in 120 seconds after turning the relay on when running in MODE ONE the display shows F.

Solar panel overheat protection

When the measured temperature of 80 °C is exceeded at the source sensor A, the controller displays **P** and switches relay on. This keeps relay on until the temperature has dropped for 5 °C. Note, target temperature could be heated over the adjusted $T_{\text{heat_to}}$ value. This function is only active in MODE ONE.

Relay delay protection

When operating in MODE ONE, MODE TWO or MODE THREE the delay protection make sure that relay always stays in same state for at least half a minute.

Nighttime cooling

On warmer days, during absence or when there is no consumption of sanitary water, the water in tank can be heated to a higher temperature than the day before after each day. In MODE ONE (differential thermostat) the controller will switch the relay on in order to cool the hot water (at night) through solar collectors.

The relay will switch on when the following two conditions are met: the temperature of the water tank

T_B for 2 degrees greater than the desired temperature T_{cool_to} , i.e. $T_B \geq T_{cool_to} + 2$, and the source has for Δ_{ON} lower temperature than in the wather tank, i.e. $T_A + \Delta_{ON} \leq T_B$. When the difference $T_B - T_A$ becomes smaller or equal to Δ_{OFF} , the relay turns off.

To switch this option off set T_{cool_to} to higher value in configuration.

Running hours counter

The controller counts the seconds of its operation and of the relay output activity. Moreover, it also counts the minutes the relay was on in last two hours (if the controller is already running for two hours). These values are shown in [debug mode](#) and are lost at power loss. Furthermore, the controller also counts full hours of its operation and of its relay output. These two last values are not lost at power loss.

Anti-stop

When operating in MODE ONE (differential thermostat) the controller activates a relay for 30 seconds every 4th day to prevent the pump from jamming. This option is disabled by default.

Configuration

To configure the controller press left button – SELECT/CONFIG – at default view. Depending on selected option, there could be plus (+), minus (–), or arrow sign (→) before its name.

If a option has numeric type, its value is increased or decreased by right – UP/DOWN – button, depending on sign, otherwise the button iterates between values.

To change the sign and move to next option use SELECT/CONFIG button. To change the sign from minus

(–) back to plus (+) or move to previous option hold left button.

After the end of configuration options or at backlight shut down the display returns to default view and configuration is saved.

Options: $\Delta 1$ and $\Delta 2$

These two configuration options represent turn on and turn off difference – hysteresis. It is advisable, that values of $\Delta 1$ and $\Delta 2$ differ for at least 2 °C.

Options: Start T and Stop T

Start T (T_{start}) and Stop T (T_{stop}) values define required temperature to start operating and sufficient temperature to keep it running, respectively. This function is operating only when running in MODE ONE and it is useful when the controller is operating with oil or wood furnace and this .

Options: Heat to and Cool to

Heat to (T_{heat_to}) represents maximal desired temperature of water storage tank in MODE ONE (differential thermostat) and target temperature in MODE TWO (thermostat for heating).

Cool to (T_{cool_to}) represents maximal desired temperature of water storage tank in the morning and also target temperature in MODE THREE (thermostat for cooling).

Option: Offset

If the value of sensor is too high or too low, this could be improved by setting sufficient offset.

Option: Invert output

With this setting the state of output relay is inverted. When the manual says the relay will be on, it will be off.

Options: Sensors type

By default, controller at power on detects the type

of sensors used. If it fails these two options could override its detection.

Option: Run on error

This option controls the relay output at error, e.g. missing sensors. By default the output turns on, thus protecting energy source. This safety option could be turned off in configuration (setting: –) or changed so that relay output switches off in case of error (setting: NO). When controller turns devices, e.g. heater, only on, it is recommended to set this to NO.

Option: Run 4th day

This setting turns on Anti-stop function.

Summary

The summary of available options, with theirs default values in bold, in the following table.

setting	values
$\Delta 1$	from 1.0 to 20.0 °C, 6.0 °C
$\Delta 2$	from 1.0 to 20.0 °C, 2.0 °C
Program	OFF , ON, M1, heating, cooling
Start T	from 6.0 to 60.0 °C, 32.0 °C
Stop T	from 6.0 to 60.0 °C, 30.0 °C
Heat to	from 6.0 to 90.0 °C, 70.0 °C
Cool to	from 30.0 to 90.0 °C, 60.0 °C
Offset A	from –2.0 to 2.0 °C, 0.0 °C
Offset B	from –2.0 to 2.0 °C, 0.0 °C
Invert output	NO , YES
Sensor A	automatic , DS1820, NTC10k
Sensor B	automatic , DS1820, NTC10k
Run on error	NO, YES , –
Run 4th day	NO , YES

All numeric values are adjustable in 0.5 °C steps.

Installation

When used as a controller for water pump, the first (source) sensor is fitted to the non-insulated outlet pipe of the solar heating panel (usually on the roof), and the second sensor under the insulation on the side of the hot water tank. For any other differential thermostat applications — e.g. turning on a fan to drive warm air from a sunny conservatory into the rest of the house, the first sensor is to be located at the heat source, and the second sensor at the location to be heated. Since the source is warmer than sink, for source sensor high temperature resistant sensor should be used.

The most common way to install the controller is by attaching it on the wall at eye level and its wiring as well. First, open the controller by loosening four screws, and disconnect front display panel by disconnecting ribbon cable. Then unscrew two (or four) screws to remove the circuit board. Attach the case to the wall (with screws) and fill holes with rubber parts. Put circuit board back on.

Cable extensions, up to 10 m length, should be made with cables from 0.25 mm² to 0.75 mm² for sensors, and from 2 × 0.75 mm² to 2 × 1.5 mm² for mains and pump.

All wires must go through four glands at the side (usually bottom) of the case. Power input (mains AC 230 V) wires are connected to the screw terminal named **POWER**. Water pump (or an additional external relay for more power-demanding devices) is connected directly to the output screw terminal named **PUMP** and it's protected by a fuse. In other words, this screw terminal outputs main voltage. Connect the source temperature sensor – sensor A – to screw terminal **IN A** and sink temperature sensor – sensor B – to **IN B**.

Sensor B when running in MODE TWO is not required.

Analog, two pin, sensors use left two pins ① and ②, colors are not important.

Digital, three pin, sensors use all three pins, where wire color of sensors is important. Wires of supplied sensors might come in two different color arrangements: green, white and brown or black, yellow and red. Connect as follows: **green** ①, **white** ② and **brown** wire ⊕ or **black** ①, **yellow** ② and **red** wire ⊕.

Input pins for both terminals are labeled in the picture on the last page. Plus sign is also printed on circuit board.

Connect display unit back (using ribbon cable), close the controller and apply power to the controller.

At first powering on, the controller will load default values and detect type of sensors: digital (DS18B20) or analog (NTC10k) and start running mode: MODE OFF (manual off), but to make the controller more reliable set sensor types in the configuration.

Troubleshooting

At the default view, values of the two temperature sensors are displayed; or a question mark (?), when sensor could not be detected; or (**M**), when sensor is missing; or (**X**), when sensor wires are in short circuit; or a dash (–) in case of sensor error reading. Moreover, the controller will display **E** when a running mode is unable to access sensor reading and make a decision. In this case output relay status is defined by configuration: "Run on error".

If sensor is present, but error persists, check cable and joints. In case of automatic sensor detection, sensor must be present at powering the controller on.

This, automatic sensor detection, could be turned off in the configuration. Then make sure you selected right option: DS1820 for digital three pin sensor and NTC10k for analog two pin sensor.

Debugging

The controller has a debug mode build-in that could be accessed from the default view by long-pressing UP/DOWN button. To display next page – move between values – press shortly the same button again.

The following values are shown (in this sequence): relay activity in last 2 hours, current uptime, running hours counters, software revision and build date, input and output status, ADC values.

Warning

When working on the controller and the connected consumers (heating/cooling devices) all poles of the mains voltage must be disconnected first!

Do not expose a digital temperature probe with PVC wires to temperatures higher than 80 °C and longterm higher than 70 °C. Do not expose an analog temperature probe with silicone wires to temperatures higher than 130 °C.

Limited liability

We take no liability for damage that occurred at device installation, during power outage, or due to misconfiguration. Solar systems should be equipped with all necessary safety elements, e.g. pressure relief valve, and filled with antifreeze, e.g. glycol, or emptied when heat transfer liquid inside the system might freeze to prevent damages.

Wiring diagram

In the figure below is a wiring diagram with marked connection points for input A (IN A - sensor A, collector), input B (IN B - sensor B, water storage tank), power supply (POWER) and pump (PUMP) . The terminal points for the sensor B (IN B) are identical to the sensor connection points A (IN A). The connection and the color codes of the sensor are listed in the table.

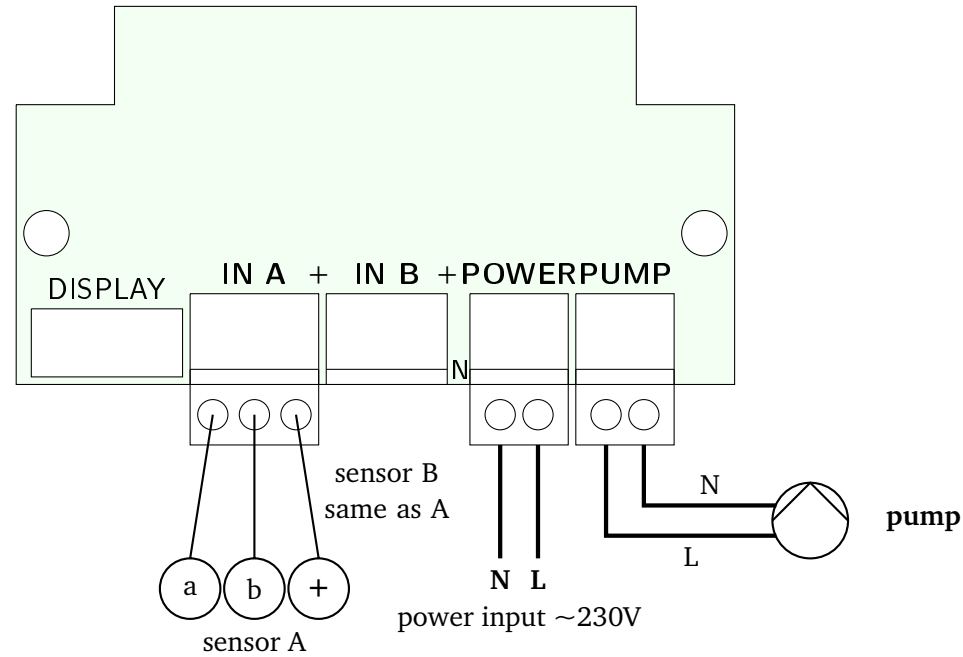

DS18B20 (3 pin)

pin	color	description
Ⓐ	green or black	ground
Ⓑ	white or yellow	data
⊕	brown or red	VCC

NTC10k (2 pin)

pin	color	description
Ⓐ	brown or red	pole 1
Ⓑ	white or blue	pole 2